

Original XBee Pin Assignments

- 1 VCC
- 2 DOUT
- 3 DIN / nCONFIG
- 4 DO8
- 5 nRESET
- 6 PWM0/RSSI
- 7 PWM1
- 8 [reserved]
- 9 nDTR/SLEEP_RQ/DI8
- 10 GND

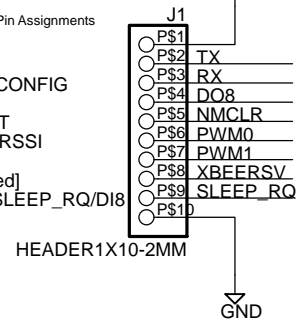

Original XBee Pin Assignments

- 20 AD0/DIO0
- 19 AD1/DIO1
- 18 AD2/DIO2
- 17 AD3/DIO3
- 16 nRTS/DIO6
- 15 Associate/AD5/DIO5
- 14 VREF
- 13 ON/nSLEEP
- 12 nCTS/DIO7
- 11 AD4/DIO4

